

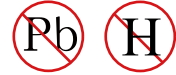

ISOLATION SUPERFAST RECOVERY RECTIFIER



VOLTAGE- 50 to 400 Volts CURRENT - 16.0 Ampere

FEATURES

- Plastic package has Underwriters Laboratory Flammability Classification 94V-0. Flame Retardant Epoxy Molding Compound.
- Exceeds environmental standards of MIL-S-19500/228
- Low power loss, high efficiency.
- Low forward voltage, high current capability
- High surge capacity.
- Super fast recovery times, high voltage.
- Epitaxial chip construction.
- High temperature soldering : 260°C / 10 seconds at terminals
- Pb free product at available : 99% Sn above meet RoHS environment substance directive request

MECHANICAL DATA

- Case: ITO-220AB Molded plastic
- Terminals: Lead solderable per MIL-STD-202, Method 208
- Polarity: As marked.
- Standard packaging: Any

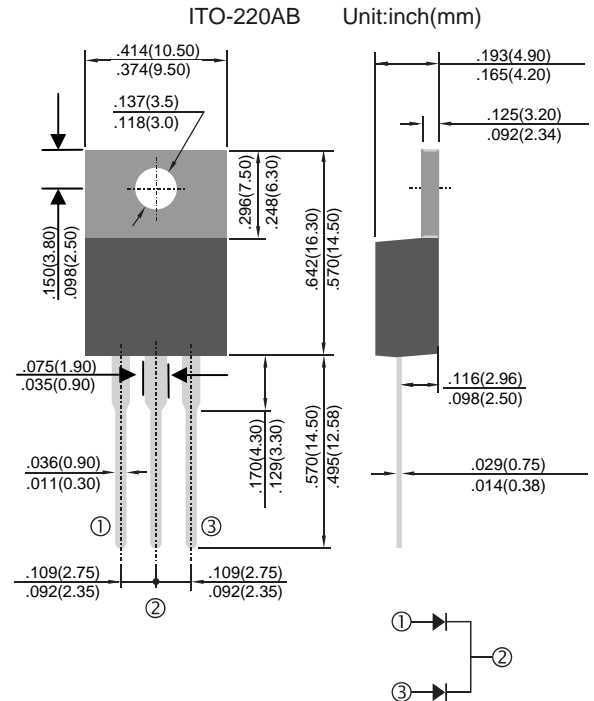

MAXIMUM RATINGS AND ELECTRICAL CHARACTERISTICS

Ratings at 25°C ambient temperature unless otherwise specified.

Single phase, half wave, 60 Hz, resistive or inductive load.

For capacitive load, derate current by 20%

	SF1601FCT	SF1602FCT	SFR1603FCT	SF1604FCT	SF1605FCT	SF1606FCT	UNITS
Maximum Recurrent Peak Reverse Voltage	50	100	150	200	300	400	V
Maximum RMS Voltage	35	70	105	140	210	280	V
Maximum DC Blocking Voltage	50	100	150	200	300	400	V
Maximum Average Forward Rectified Current at Tc=90°C	16						A
Peak Forward Surge Current , 8.3 ms single half sine-wave super imposed on rated load (JEDEC method)	125						A
Maximum Instantaneous Forward Voltage at 8.0A per element	0.95				1.30		V
Maximum DC Reverse Current (Note 1) Ta=25°C at Rated DC Blocking Voltage Ta=125°C	10 500						µA
Typical Junction Capacitance (Note 1)	62						pF
Maximum Reverse Recovery Time (Note 2)	35				50		nS
Typical Thermal Resistance (Note 3) RθJC	3.0						°C/W
Operating and Storage Temperature Range TJ, TSTG	-55 to +150						°C

NOTES:

1. Measured at 1 MHz and applied reverse voltage of 4.0 VDC.
2. Reverse Recovery Test Conditions: IF=.5A, IR=1A, Irr=.25A.
3. Thermal Resistance Junction to CASE.

# DEVICE CHARACTERISTICS

## SF1600FCT THRU SF1606FCT

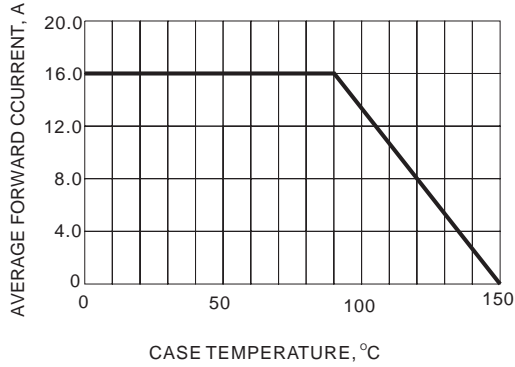

Fig.1- FORWARD CURRENT DERATING CURVE

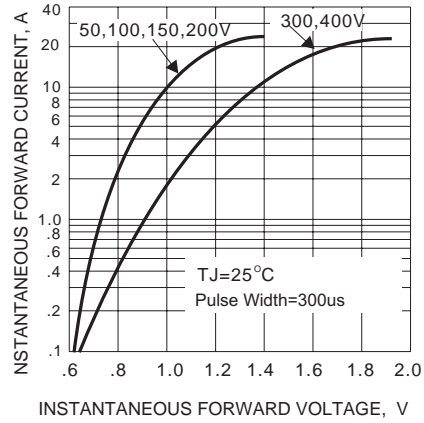

Fig.2- TYPICAL INSTANTANEOUS FORWARD CHARACTERISTIC

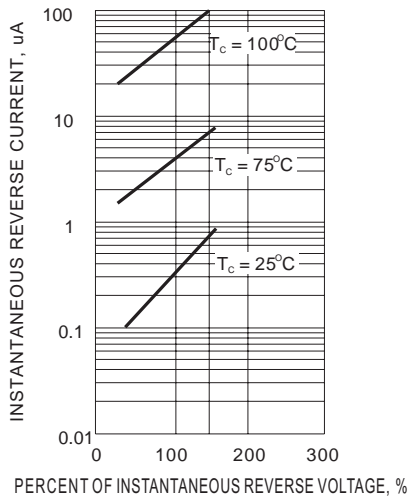

Fig.3 TYPICAL REVERSE CHARACTERISTIC

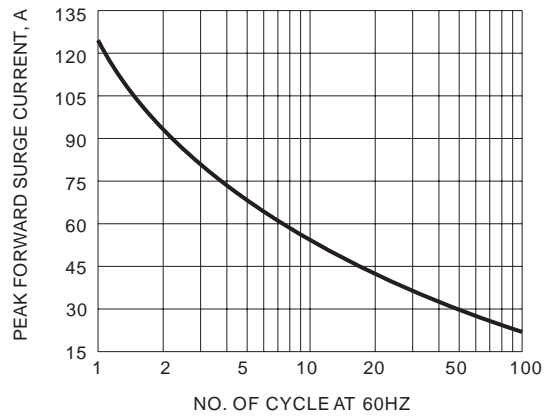

Fig.4- MAXIMUM ON-REPETITIVE SURGE CURRENT

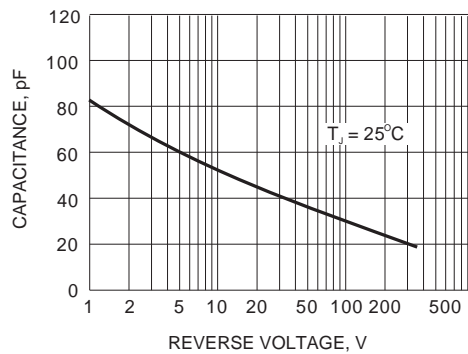

Fig.5- TYPICAL JUNCTION CAPACITANCE