



DATA SHEET

SEMICONDUCTOR

MMBT2907 & MMBT2907A

General Purpose Transistor

PNP Silicon

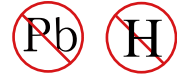

MAXIMUM RATINGS

Rating	Symbol	Value		Unit
		2907	2907A	
Collector–Emitter Voltage	V_{CEO}	-40	-60	Vdc
Collector–Base Voltage	V_{CBO}	-60		Vdc
Emitter–Base Voltage	V_{EBO}	-5.0		Vdc
Collector Current — Continuous	I_C	-600		mAdc

THERMAL CHARACTERISTICS

Characteristic	Symbol	Max	Unit
Total Device Dissipation FR– 5 Board, (1) $T_A = 25^\circ\text{C}$	P_D	225	mW
Derate above 25°C		1.8	mW/ $^\circ\text{C}$
Thermal Resistance, Junction to Ambient	$R_{\theta JA}$	556	$^\circ\text{C/W}$
Total Device Dissipation Alumina Substrate, (2) $T_A = 25^\circ\text{C}$	P_D	300	mW
Derate above 25°C		2.4	mW/ $^\circ\text{C}$
Thermal Resistance, Junction to Ambient	$R_{\theta JA}$	417	$^\circ\text{C/W}$
Junction and Storage Temperature	T_J, T_{stg}	-55 to +150	$^\circ\text{C}$

DEVICE MARKING

MMBT2907 = M2B, MMBT2907A = 2F

CASE 318–08, STYLE 6
SOT-23 (TO-236AB)

ELECTRICAL CHARACTERISTICS ($T_A = 25^\circ\text{C}$ unless otherwise noted.)

Characteristic	Symbol	Min	Max	Unit
----------------	--------	-----	-----	------

OFF CHARACTERISTICS

Collector–Emitter Breakdown Voltage(3) ($I_C = -10\text{ mAdc}, I_E = 0$)	$V_{(BR)CEO}$			Vdc
	MMBT2907	-40	—	
	MMBT2907A	-60	—	
Collector–Emitter Breakdown Voltage($I_C = -10\ \mu\text{Adc}, I_E = 0$)	$V_{(BR)CBO}$	-60	—	Vdc
Emitter–Base Breakdown Voltage($I_E = -10\ \mu\text{Adc}, I_C = 0$)	$V_{(BR)EBO}$	-5.0	—	Vdc
Collector Cutoff Current($V_{CB} = -30\text{Vdc}, I_{BE(OFF)} = -0.5\text{Vdc}$)	I_{CEX}	—	-50	nAdc
Collector Cutoff Current ($V_{CB} = -50\text{Vdc}, I_E = 0$)	I_{CBO}			μAdc
	MMBT2907	—	-0.020	
	MMBT2907A	—	-0.010	
($V_{CB} = -50\text{Vdc}, I_E = 0, T_A = 125^\circ\text{C}$)				
	MMBT2907	—	-20	
	MMBT2907A	—	-10	
Base Current($V_{CE} = -30\text{Vdc}, V_{EB(OFF)} = -0.5\text{Vdc}$)	I_B	—	-50	nAdc

1. FR-5 = $1.0 \times 0.75 \times 0.062$ in.

2. Alumina = $0.4 \times 0.3 \times 0.024$ in. 99.5% alumina.

3. Pulse Test: Pulse Width $\leq 300\ \mu\text{s}$, Duty Cycle $\leq 2.0\%$.

SOT-23 (TO-236AB)

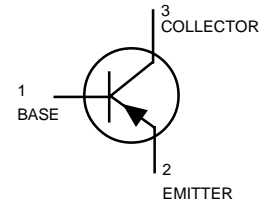
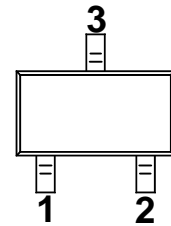

ELECTRICAL CHARACTERISTICS

MMBT2907 & MMBT2907A

ELECTRICAL CHARACTERISTICS ($T_A = 25^\circ\text{C}$ unless otherwise noted) (Continued)

Characteristic	Symbol	Min	Max	Unit
ON CHARACTERISTICS				
DC Current Gain ($I_C = -0.1\text{mA dc}$, $V_{CE} = -10\text{V dc}$)	h_{FE}	35	—	—
		MMBT2907	75	—
($I_C = -1.0\text{mA dc}$, $V_{CE} = -10\text{V dc}$)		50	—	
		MMBT2907A	100	—
($I_C = -10\text{mA dc}$, $V_{CE} = -10\text{V dc}$)		75	—	
		MMBT2907A	100	—
($I_C = -150\text{mA dc}$, $V_{CE} = -10\text{V dc}$)(3)		—	—	
		MMBT2907A	100	300
($I_C = -500\text{mA dc}$, $V_{CE} = -10\text{V dc}$)(3)		30	—	
		MMBT2907A	50	—
Collector-Emitter Saturation Voltage(3) ($I_C = -150\text{mA dc}$, $I_B = -15\text{mA dc}$) ($I_C = -500\text{mA dc}$, $I_B = -50\text{mA dc}$)	$V_{CE(sat)}$	—	-0.4	Vdc
		—	-1.6	
Base-Emitter Saturation Voltage(3) ($I_C = -150\text{mA dc}$, $I_B = -15\text{mA dc}$) ($I_C = -500\text{mA dc}$, $I_B = -50\text{mA dc}$)	$V_{BE(sat)}$	—	-1.3	Vdc
		—	-2.6	

SMALL-SIGNAL CHARACTERISTICS

Current-Gain — Bandwidth Product(3),(4) ($I_C = -50\text{mA dc}$, $V_{CE} = -20\text{V dc}$, $f = 100\text{MHz}$)	f_T	200	—	MHz
Output Capacitance ($V_{CB} = -10\text{V dc}$, $I_E = 0$, $f = 1.0\text{MHz}$)	C_{obo}	—	8.0	pF
Input Capacitance ($V_{EB} = -2.0\text{V dc}$, $I_C = 0$, $f = 1.0\text{MHz}$)	C_{ibo}	—	30	pF

SWITCHING CHARACTERISTICS

Turn-On Time	$(V_{CC} = -30\text{V dc}$, $I_C = -150\text{mA dc}$, $I_{B1} = -15\text{mA dc}$)	t_{on}	—	45	
Delay Time		t_d	—	10	ns
Rise Time		t_r	—	40	
Fall Time	$(V_{CC} = -6.0\text{V dc}$, $I_C = -150\text{mA dc}$, $I_{B1} = I_{B2} = 15\text{mA dc}$)	t_f	—	30	
Storage Time		t_s	—	80	ns
Turn-Off Time		t_{off}	—	100	

3. Pulse Test: Pulse Width $\leq 300\ \mu\text{s}$, Duty Cycle $\leq 2.0\%$.

4. f_T is defined as the frequency at which $|h_{fe}|$ extrapolates to unity.

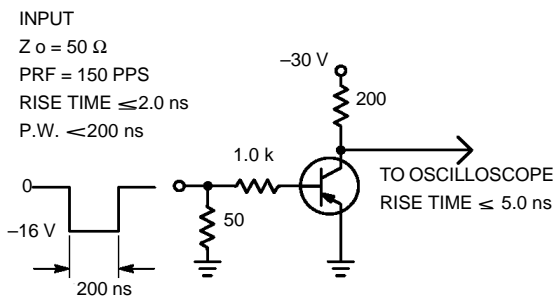

Figure 1. Delay and Rise Time Test Circuit

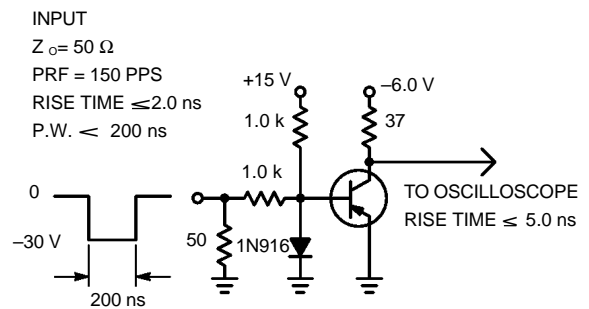

Figure 2. Storage and Fall Time Test Circuit

DEVICE CHARACTERISTICS

MMBT2907 & MMBT2907A

TYPICAL CHARACTERISTICS

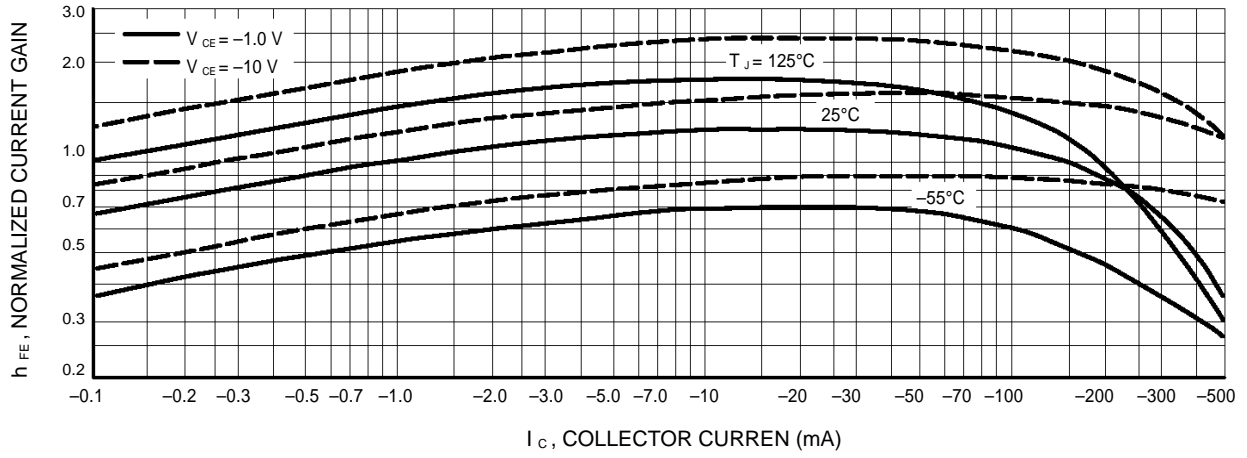

Figure 3. DC Current Gain

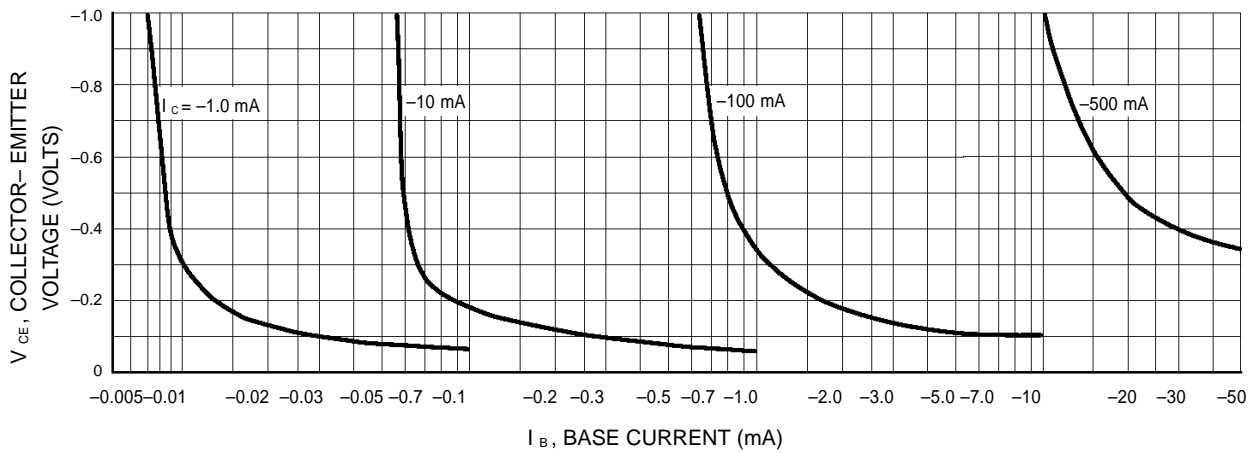

Figure 4. Collector Saturation Region

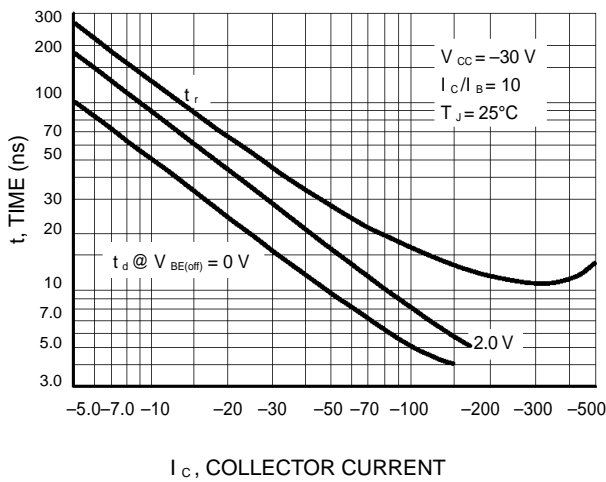

Figure 5. Turn-On Time

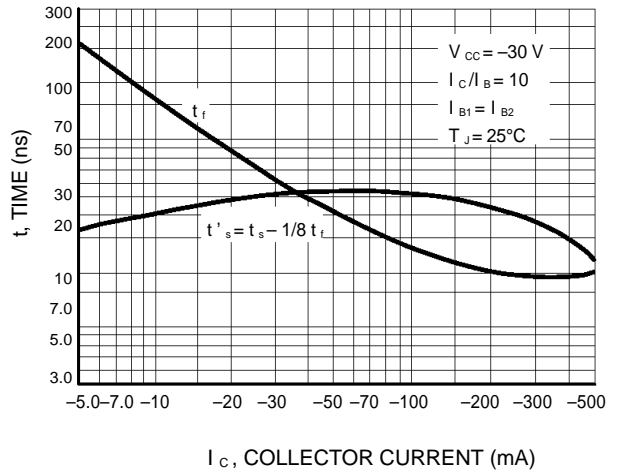

Figure 6. Turn-Off Time

DEVICE CHARACTERISTICS

MMBT2907 & MMBT2907A

TYPICAL SMALL-SIGNAL CHARACTERISTICS

NOISE FIGURE

$V_{CE} = 10 \text{ Vdc}$, $T_A = 25^\circ\text{C}$

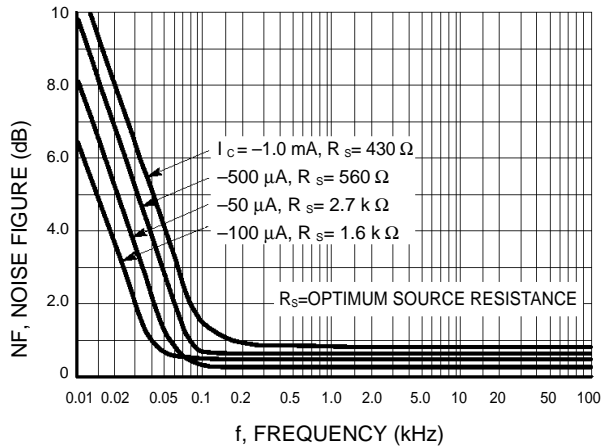

Figure 7. Frequency Effects

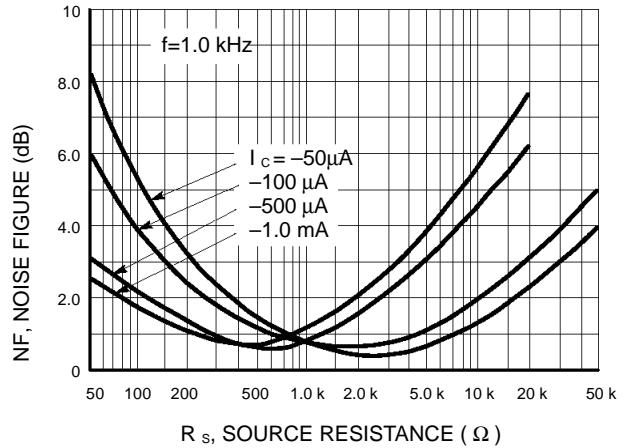

Figure 8. Source Resistance Effects

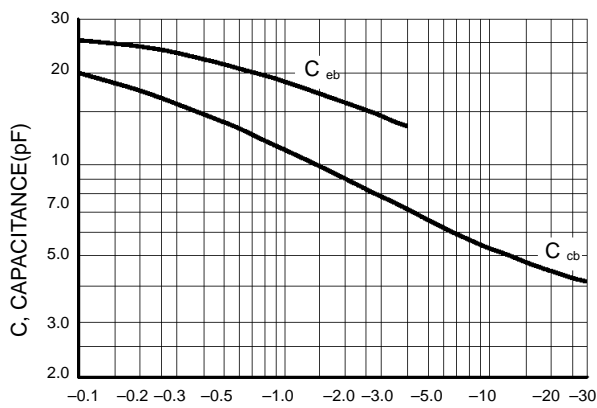

Figure 9. Capacitances

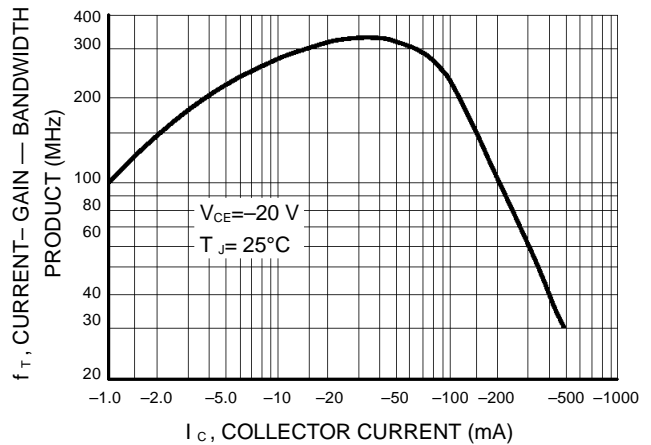

Figure 10. Current-Gain — Bandwidth Product

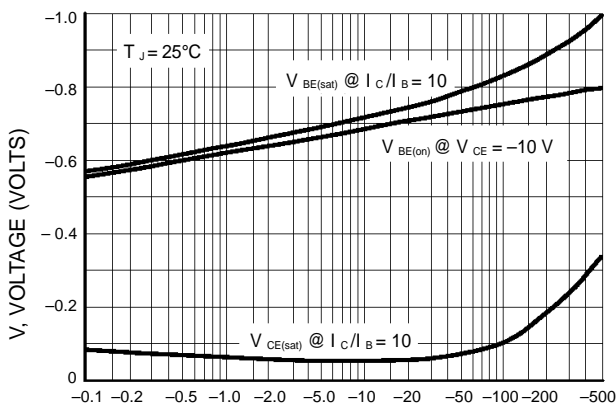

Figure 11. "On" Voltage

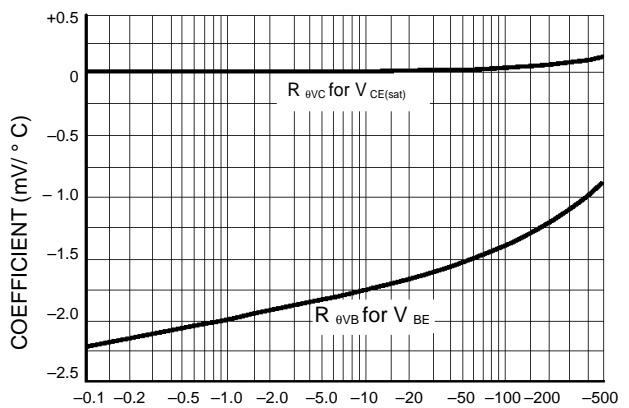
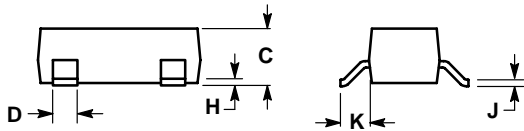
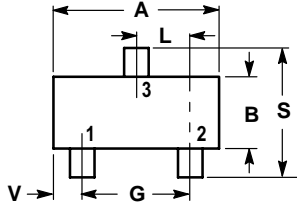

Figure 12. Temperature Coefficients

PACKAGE OUTLINE & DIMENSIONS

MMBT2907 & MMBT2907A

SOT-23



NOTES:

1. DIMENSIONING AND TOLERANCING PER ANSI Y14.5M, 1982.
2. CONTROLLING DIMENSION: INCH.

DIM	INCHES		MILLIMETERS	
	MIN	MAX	MIN	MAX
A	0.1102	0.1197	2.80	3.04
B	0.0472	0.0551	1.20	1.40
C	0.0350	0.0440	0.89	1.11
D	0.0150	0.0200	0.37	0.50
G	0.0701	0.0807	1.78	2.04
H	0.0005	0.0040	0.013	0.100
J	0.0034	0.0070	0.085	0.177
K	0.0140	0.0285	0.35	0.69
L	0.0350	0.0401	0.89	1.02
S	0.0830	0.1039	2.10	2.64
V	0.0177	0.0236	0.45	0.60

